

# Hydrostatic Tool Design and Specifications

## Ball size

The HG line features tools in a wide range of sizes with burnishing balls from 2 – 25 mm in diameter. The tools are classified according to approximate ball size. For example, the diameter of a ball in an HG6 tool is in the 6 mm range. To maximize the level of compressive residual stresses, use the tool with the largest possible ball diameter.

**NOTE:** Workpiece contours ultimately determine ball size.

HG ball size	Max. burnishing force	Max. angle range ( $\beta$ )	Stroke (s)	Length (l)
HG2	90N	$\pm 22.5^\circ$	2 mm	35 mm
HG3	250N	$\pm 22.5^\circ$	4 mm	42 mm
HG4	500N	$\pm 30^\circ$	5 mm	50 mm
HG6	1000N	$\pm 30^\circ$	6 mm	50 mm
HG13	4000N	$\pm 35^\circ$	8.5 mm	69 mm
HG25	4000N	$\pm 30^\circ$	8.5 mm	82 mm

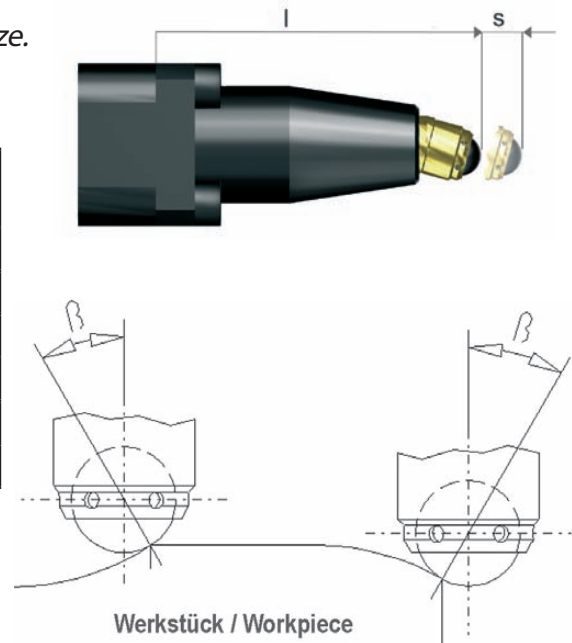

## Design version

Because HG tools can be used across a wide spectrum of applications, many different design versions are available. HG tools are classified by design version in addition to ball size. For example, an HG6-2 tool has a ball with a 6 mm diameter and is used for burnishing inner diameters. The following table lists the design versions and their related applications.

**NOTE:** The tools are listed as follows: HGx-y, where **x** indicates the ball size and **y** the design version.

HG design version	Application
HGx-1	internal diameters (cylindrical and tapered bores)
HGx-2	internal diameters (cylindrical bores)
HGx-4	internal diameters (narrow cylindrical bores)
HGx-5	complex contours (cylinders, tapers, faces, fillets, spheres)
HGx-6	spherical contours
HGx-7	faces and free-form surfaces
HGx-9	rotationally symmetrical surfaces (cylinders, tapers, faces, fillets, spheres)
HGx-10	spherical contours
HGx-11	special tool design versions (e.g. internal diameters – narrow cylindrical bores)
HGx-19	rotationally symmetrical surfaces (cylinders, tapers, faces, radii, slanted faces and other outer and inner contours)
HGx-20	3-point tool (3 burnishing balls), outer diameters of narrow cylinders
HGx-23	Complex external surfaces (such as transition area near steering knuckle radius)
HGx-29	2-point tool (2 burnishing balls), treats both sides of disc-like and thin-walled components (such as turbine blades) in one pass